

Joint de dilatation de sol tout métal pour extérieur et intérieur permettant les mouvements de dilatation et de contraction ainsi que les mouvements verticaux et de cisaillement. Pour tous types de finitions : dalle, chape, carrelage, marbre...

*All metal floor expansion joint for exterior and interior use, allowing expansion and contraction of the joint as well as vertical movement and unlimited shear movement. For all types of finishes: screed, natural stone, cast stone, marble...*

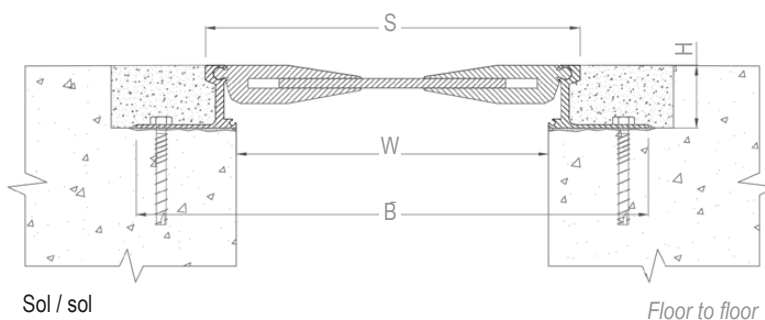

**JDH 6.16**



Ref. JDH 6.16	6.16-250
W [mm] Ouverture jusqu'à / Gap up to	250
H [mm] Hauteur / Depth	50 / 80
S [mm] approx.	300
B [mm] approx.	410
Mouvements admissibles [mm] <i>Movement capacities [mm]</i>	+50 / -50
Matériau / Material	Aluminium / Aluminium
Longueur standard [ml] / Standard length [lm]	2
Charges <i>Load-bearing capacities</i>	

Existe aussi en version sol/mur. / Floor to wall profile also available.

Fixations : nous consulter pour préconisation. / Fixings: please contact us for technical recommendation.

The load-bearing capacity is always indicated for a joint in its initial position. In case of opening movements, the load-bearing capacity significantly reduces and the product will thus be only adapted for a light pedestrian traffic. The indicated load-bearing capacities are based on pneumatic wheels vehicles with a contact surface of 200x200 mm.

© All rights reserved - Non contractual drawings - 11/2021