

Joint de dilatation de sol tout métal

All metal floor expansion joint

Series JDH 6.11

Joint de dilatation de sol tout métal pour extérieur et intérieur. Constitué de 2 cornières en aluminium permettant les mouvements de dilatation et de contraction ainsi que les mouvements verticaux et de cisaillement. Spécial carrelage, pierre et céramique en pose collée.

All metal floor expansion joint for exterior and interior. Made of 2 aluminium side plates allowing expansion and contraction of the joint as well as vertical movement and shear movement. Spacial for adhesive affixed tiles, stone and ceramic floor.

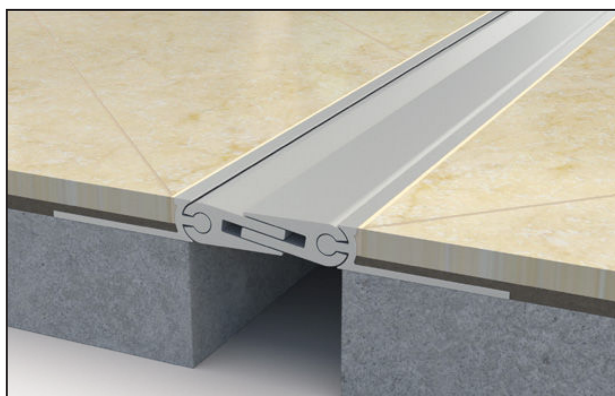
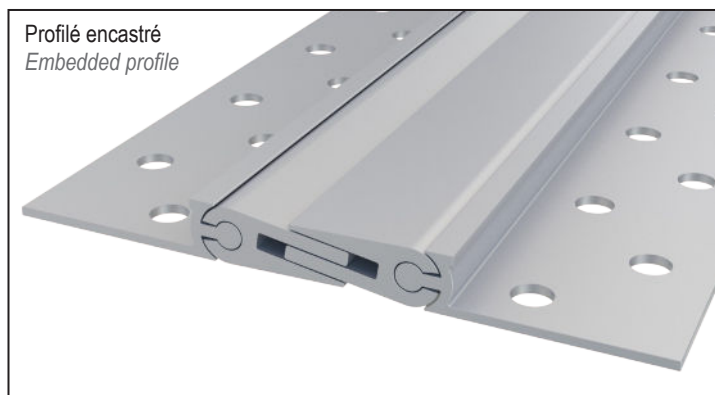

JDH 6.11

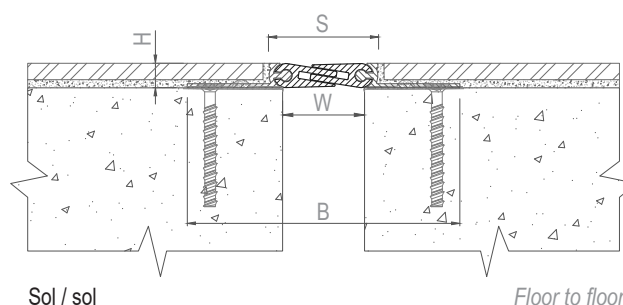

Ref. JDH 6.11	6.11-040
W [mm] Ouverture jusqu'à / Gap up to	40
H [mm] Hauteur / Depth	12
S [mm] approx	53
B [mm] approx	133
Mouvements admissibles [mm] <i>Movement capacity [mm]</i>	+12 / -12
Matériau / Material	Aluminium / Aluminium
Charges <i>Load-bearing capacity</i>	

Finitions : aluminium lisse spécialement / *Finishes: specially smooth aluminum.*

Fixations : nous consulter pour préconisation. / *Fixings: please contact us for technical recommendation.*

© All rights reserved - Non contractual drawings - 03/2022

Certified management system



GV2 VEDA FRANCE

20, Allée des Erables - Bât. E - 93420 Villepinte - France

Postal Address

CS 63052 - 95972 Roissy CDG Cedex

Tel : + 33 (0)1 48 61 70 80

Fax : + 33 (0)1 48 61 70 81

E-mail : contact@vedafrance.com

Web : www.vedafrance.com