



VEDA FRANCE

Jointes bâtiment - Building joints

Joint de dilatation de sol tout métal

All metal floor expansion joint

Series JDH 6.36

Joint de dilatation de sol tout aluminium pour extérieur et intérieur. Pour tous types de finition : dalle, chape, carrelage, marbre...

Aluminium floor expansion joint for exterior and interior use. For all types of finishes : screed, natural stone, cast stone, marble...



JDH 6.36

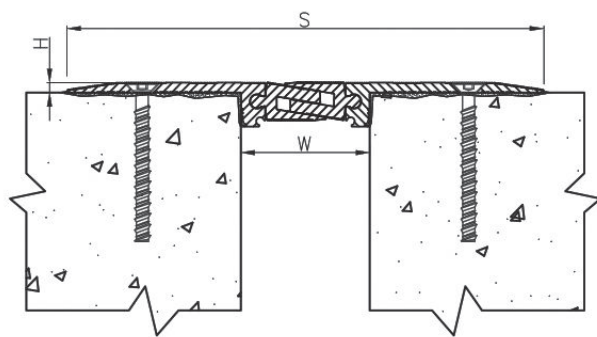

Sol / sol



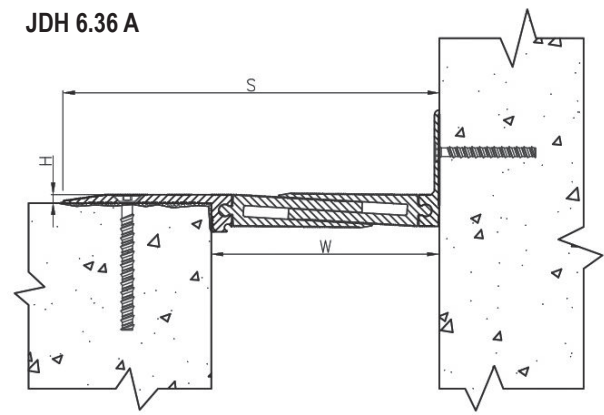

Floor to floor

JDH 6.36 A



Sol / mur

Floor to wall

Ref. JDH 6.36	6.36-065	6.36-065 A	6.36-090	6.36-090 A	6.36-110	6.36-110 A	6.36-135	6.36-135 A
W [mm] Ouverture jusqu'à / Gap up to	65		90		110		135	
H [mm] Hauteur / Height	5							
S [mm] approx.	240	153	265	178	285	198	310	223
Mouvements admissibles [mm] Movement capacity [mm]	+7 / -7		+15 / -15		+20 / -20		+25 / -25	
Matériau / Material	Aluminium / Aluminium							
Longueur standard [ml] / Standard length [m]	3							
Charges [kN] Load-bearing capacity [kN]								

Fixations : nous consulter pour préconisation. / Fixings : please contact us for technical recommendation.

Veillez nous consulter pour vérifier l'utilisation du produit avec des engins à roues non pneumatiques. / Please contact us in case of traffic of vehicles with non-pneumatic wheels.

The load-bearing capacity is based on the initial position of the joint. The indicated load-bearing capacities are based on pneumatic wheels vehicles with a contact surface of 200x200 mm.

© All rights reserved - Non contractual drawings - 10/2023

Certified management system



GV2 VEDA FRANCE

20, Allée des Erables - Bât. E - 93420 Villepinte - France

Postal Address

CS 63052 - 95972 Roissy CDG Cedex

Tel : + 33 (0)1 48 61 70 80

Fax : + 33 (0)1 48 61 70 81

E-mail : export@vedafrance.com

Web : www.vedafrance.com