

# Joint de dilatation de sol tout métal All metal floor expansion joint

JDH 6.40

Joint de dilatation de sol sismique tout métal spécial carrelage et pierre pour extérieur et intérieur.

All metal seismic floor expansion joint special for tiles and stone floor for exterior and interior.

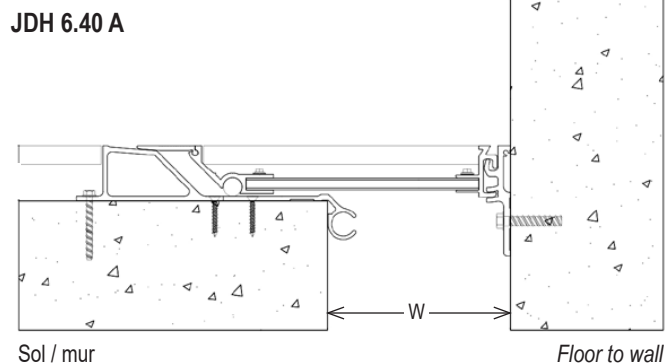
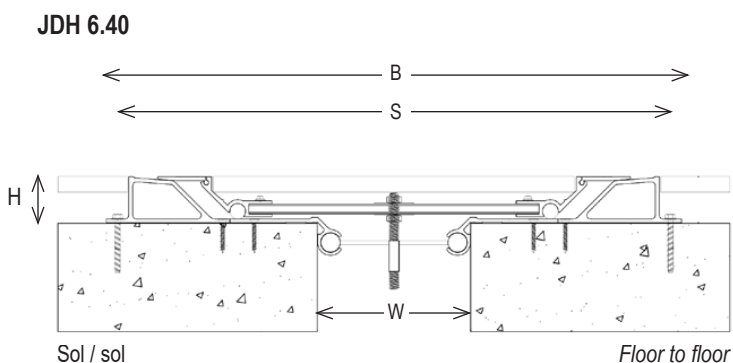

JDH 6.40	6.40-075	6.40-100	6.40-150	6.40-200	6.40-250	6.40-300	6.40-400	6.40-500	6.40-600	6.40-850
W [mm] Ouverture jusqu'à / Gap up to	75	100	150	200	250	300	400	500	600	850
H [mm] Hauteur / Height	60									
S [mm] approx.	441	466	557	691	742	792	892	992	1092	1642
B [mm] approx.	510	525	616	750	800	850	950	1050	1150	1701
Mouvements admissibles [mm] Movement capacity [mm]	+40 / -20	+50 / -50	+75 / -75	+100 / -100	+125 / -125	+150 / -150	+200 / -200		+400 / -400	
Matériau / Material	Aluminium									
Longueur standard [m] / Standard length [m]	3									
Charges Load-bearing capacity										

Fixations : nous consulter pour préconisation. / Fixings: please contact us for technical recommendation.